

ISUZU
THE PICK-UP
PROFESSIONALS

The New Isuzu D-Max

EV Range



isuzu.co.uk/ev

The New Isuzu D-Max EV

Fully electric. Fully capable.

No emissions. No compromises.

The complete package, delivering all the pick-up power and 4x4 performance you need.

The New Isuzu D-Max EV is the latest evolution of our award-winning platform, re-engineered with an advanced electric drivetrain. Same 1 tonne payload and 3.5 tonne towing capacity. Same full-on commercial capability.

3.5
TONNE
TOWING
CAPACITY

—OVER—
1.0
TONNE
PAYLOAD

FULL
TIME
4 WHEEL
DRIVE

3%
BIK
RATE

100%
CAPITAL
ALLOWANCE

VAT
BACK
QUALIFIED

5 YEAR
125K MILE
WARRANTY

8 YEAR
100K MILE
BATTERY
WARRANTY

5 year / 125,000 miles (whichever comes first) warranty applies to all new Isuzu D-Max models.

Power full by design

Combining style and strength, The New Isuzu D-Max EV features sophisticated enhancements like distinctive Bi-LED headlights with a blue accent, new Colour LED Rear Combination lights, and EV badging on the front fenders and tailgate.

The eDL40 sports a newly designed dark grey and chrome radiator grille, two-tone silver side steps and 18" alloy wheels. While the top of the range eV-Cross is distinguished with black side steps, a dark grey radiator grille and 'Rugged Style' 18" alloy wheels.



Joy full journeys

Delivering premium comfort, the fuss-free cabin benefits from newly designed leather upholstery[^], a leather steering wheel, and 8-way electrically adjustable driver's seat. You can also look forward to heated front seats, together with dual-zone climate control.

In addition to a 7" driver display, entertainment is streamed via a fully wireless 8" or 9" Multifunction Colour Touchscreen, featuring Android Auto™ and Apple CarPlay™. And in the eV-Cross, an auto dimming rear view mirror and headlight levelling further enhance convenience.



[^]Leather and other materials.

Born electric. Built tough.

The New Isuzu D-Max EV is powered by a robust lithium-ion 66.9 kWh battery with a warranty of 8 years or 100,000 miles. This delivers a WLTP city range of 361.2km and combined range of 263km.

Dual motors produce a total output of 149.3kW (203 PS) and 347.6 Nm of torque, while full-time 4x4 with multi-level regenerative braking ensures the D-Max EV is ready for any terrain. Eco Mode extends the range further, providing a perfect balance of power and efficiency.



Duty full

A clean and capable pick-up that meets your commercial and environmental demands in equal measure.



eDL40

Available in Extended and Double Cab.



EXTERIOR

- New Design Bi-LED Headlights with Blue Accent Colour
- Automatic Headlights with High Beam Assist
- New Colour LED Rear Combination Lamp
- New Design Two Tone Titanium Grey & Dark Grey Radiator Grille
- New 18" Two Tone Alloy Wheels
- Improved Dunlop AT31 Tyres
- New Design Two Tone Silver Side Steps

INTERIOR

- Leather Upholstery*
- Driver's Seat Lumbar Support (Power)
- Heated Front Seats
- 8-Way Adjustable Driver's Seat (Electric)
- Leather Steering Wheel

ENTERTAINMENT

- 8" Multifunction Colour Touchscreen
- Bluetooth® Connectivity
- DAB Radio
- Wireless Apple CarPlay™ & Android Auto™
- Six Speakers
- Front USB C Port
- Rear USB C Port (Double Cab only)

COMFORT & CONVENIENCE

- 7" Multi-Information Display
- Welcome Light
- Follow Me Home Light
- Keyless Entry & Push Button Start System
- Driver & Passenger Sun Visors with Vanity Mirror
- Steering Wheel Mounted Audio & Cruise Controls
- Dual Zone Climate Control
- Rear Ventilation Panel

SAFETY & SECURITY

- New Surround View Camera
- Front & Rear Parking Sensors
- Rough Terrain Mode
- Advanced Driver Assist System (ADAS)
- Speed-Sensitive Power Steering
- Tyre Pressure Monitoring System
- Brake Assist System
- Hill Start Assist
- Hill Descent Control
- e-Call

Master full

Designed for those who demand durability, power and practicality without compromise.



eV Cross



EXTERIOR

- New Design Bi-LED Headlights with Blue Accent Colour
- New Colour LED Rear Combination Lamp
- New Design LED Front Fog Lights
- Dark Grey Door Handles
- New Design Two Tone Titanium Grey Radiator Grille
- New Design 18" Rugged Style Matt Dark Grey Alloy Wheels
- New Design Black Side Steps

INTERIOR

- New Design Leather Upholstery*
- Piano Black Accent Colour on Steering Wheel, Dash & Doors
- 8-Way Adjustable Driver's Seat (Electric)
- Driver's Seat Lumbar Support (Power)
- Heated Front Seats
- Leather Steering Wheel

ENTERTAINMENT

- 9" Multifunction Colour Touchscreen
- Bluetooth® Connectivity
- DAB Radio
- Wireless Apple CarPlay™ & Android Auto™
- Eight Speakers
- 2 x Front USB C Ports
- Rear USB C Port

COMFORT & CONVENIENCE

- 7" Multi-Information Display
- Auto Dimming Rear View Mirror
- Welcome Light
- Follow Me Home Light
- Keyless Entry & Push Button Start System
- Steering Wheel Mounted Audio & Cruise Controls
- 12-Volt Power Outlet
- Dual Zone Climate Control
- Rear Ventilation Panel

SAFETY & SECURITY

- New Surround View Camera
- Front & Rear Parking Sensors
- Rough Terrain Mode
- Advanced Driver Assist System (ADAS)
- Speed-Sensitive Power Steering
- Tyre Pressure Monitoring System
- Brake Assist System
- Hill Start Assist
- Hill Descent Control
- e-Call

Vehicle Specification

Key: Standard Unavailable

EXTERIOR	eDL40 Extended	eDL40 Double	eV-Cross
EV Badging on Front Fenders & Tailgate			
New Design Bi-LED Headlights			
LED Daytime Running Lights			
Automatic Headlights			
Automatic Headlight Levelling	-	-	
High Beam Assist			
New Colour LED Rear Combination Lamp			
LED Front Fog Lights			
Rear Fog Lights			
Automatic Windscreen Wipers with Rain Sensor			
Heated Rear Screen			
New Design Two Tone Dark Grey & Chrome Radiator Grille			-
New Design Two Tone Titanium Grey Radiator Grille	-	-	
Body Coloured Rear Bumper with Integrated Step			
New Design Two Tone Silver Side Steps			-
New Design Black Side Steps	-	-	
Folding, Heated, Chrome Door Mirrors with Side Indicator Repeaters			-
Folding, Heated, Dark Grey Door Mirrors with Side Indicator Repeaters	-	-	
Chrome Door Handles			-
Dark Grey Door Handles	-	-	
Integrated AC (Type 2) and DC (CCS2) Charging Port			
Tailgate Damper			
WHEELS			
New Design 18" Two Tone Alloy Wheels			-
New Design 18" Rugged Style Matt Dark Grey Alloy Wheels	-	-	
Improved Dunlop AT31 Tyres			
Locking Wheel Nuts			
Full Size Spare Wheel			

INTERIOR	eDL40 Extended	eDL40 Double	eV-Cross
New Design Leather Upholstery ¹			
8-Way Adjustable Driver's Seat (Electric)			
Driver's Seat Lumbar Support (Power)			
Heated Front Seats			
Front Seatback Map Pockets			
Flat Folding Rear Seats	-		
60/40 Folding Seat Base	-		
Under Seat Base Storage			
Height Adjustable Front Headrests			
Height Adjustable Rear Headrests	-		
Front Centre Armrest			
Front Cup Holders (Centre Console & Dash - Driver & Passenger Sides)			
Front Door Pockets with Bottle Holder			
Rear Centre Armrest with Cup Holders	-		
Rear Door Pockets with Bottle Holder	-		
Leather Steering Wheel			
Driver's Foot Rest			
Carpet Floor Trim			
Carpet Mats			
ENTERTAINMENT			
8" Multifunction Colour Touchscreen			-
Updated 9" Multifunction Colour Touchscreen	-	-	
Bluetooth® Connectivity			
DAB Radio			
Wireless Apple CarPlay™ & Android Auto™			
Six Speakers			-
Eight Speakers	-	-	
Front USB C Port	-		-
2 x Front USB C Ports	-	-	
Rear USB C Port	-		

¹Leather and other materials.

COMFORT & CONVENIENCE	eDL40 Extended	eDL40 Double	eV-Cross
Remote Control Central Locking			
Welcome Light			
Follow Me Home Light			
Keyless Entry & Push Button Start System			
Power Windows (Front Only)		-	-
Power Windows (Front & Rear)	-		
Sunglasses Holder & Overhead Console			
Map Lights			
Driver & Passenger Sun Visors with Vanity Mirror			-
Driver & Passenger Sun Visors with Illuminated Vanity Mirror	-	-	
Auto Dimming Rear View Mirror	-	-	
Height & Reach Adjustable Steering Wheel			
Steering Wheel Mounted Audio & Cruise Controls			
12-Volt Power Outlet			
New 7" Multi-Information Display			
CLIMATE CONTROL			
Dual Zone Climate Control			
Rear Ventilation Panel			
ADVANCED DRIVER ASSIST SYSTEMS ²			
Attention Assist			
Autonomous Emergency Braking			
Blind Spot Monitor	-		
Emergency Lane Keeping			
Forward Collision Warning			
Intelligent Adaptive Cruise Control			
Intelligent Speed Limiter ⁴			
Lane Departure Warning & Prevention			
Lane Keep Assist			
Traffic Jam Assist			
Traffic Sign Recognition			
Turn Assist			
Traffic Sign Recognition			
Turn Assist			

SAFETY & SECURITY	eDL40 Extended	eDL40 Double	eV-Cross
New Surround View Camera			
Front & Rear Parking Sensors			
Rough Terrain Mode			
Speed-Sensitive Power Steering			
Tyre Pressure Monitoring System			
ESC (Electronic Stability Control)			
Traction Control			
ABS (Anti-Lock Braking System)			
EBD (Electronic Brakeforce Distribution)			
Brake Assist System			
Hill Start Assist			
Hill Descent Control			
E-Call			
Multi-Collision Brake			
Security Etched Glass			
Insurance Approved Immobiliser			
Alarm with Deadlock			
Front, Side, Curtain & Driver Knee SRS Airbags ⁵			
Centre SRS Airbag	-		
Passenger Airbag Deactivation Switch			
Height Adjustable Front Seatbelts with Pretensioner & Load Limiter			
2 x Three-Point Rear Seatbelts (Side)		-	-
3 x Three-Point Rear Seatbelts (Side & Centre)	-		
ISOFIX Child Seat Anchors with Top Tether Anchors (2 x Rear Side)	-		
Rear Door Child Locks	-		
Seatbelt Reminder Indicator (All Seating Positions)			
Door Open Warning Light			
Stop & Start System ⁶			

²Driver side has auto up/down function, with pinch protection and timer. ³ADAS are driving support systems which may not operate optimally under all driving conditions or for all objects. The driver is always responsible for safe and attentive driving and observance of traffic regulations. See Owner's Manual for complete details on system operation and limitations. ⁴Manual & Intelligent Speed Limiter. ⁵SRS: Supplemental Restraint System. Must be used in conjunction with seatbelts. ⁶According to conditions, the Stop & Start system will automatically stop and restart the engine when the vehicle comes to a standstill to reduce fuel consumption and emissions.

Technical Specification

POWERTRAIN	eDL40 Extended	eDL40 Double	eV-Cross
Drive system	Full-time 4x4		
Electric motor	Dual-motor system		
Total power output	149.3 kW (45.9 kW front, 103.4 kW rear)		
Torque	347.6Nm (115 Nm front, 232.6 Nm rear)		
Max speed	Over 80 mph		
Acceleration (0-62mph)	10.1 seconds		
Eco mode	Available for improved range		
Regeneration levels	4 selectable levels		

BATTERY	
Battery type	Lithium-ion
Battery capacity	66.9 kWh
Vehicle range (WLTP)	263 km
Charging (AC)	Max 11 kW - 10 hrs (0-100%)
Charging (DC)	Max 50 kW - 1 hr (20-80%)
Battery warranty	8 years / 100,000 miles

DIMENSIONS (MM)	
Length	5280
Width	1870
Height	1790
Front Overhang	905
Rear Overhang	1250
Wheelbase	3125
Track (Front & Rear)	1570
Ground Clearance	210
Wading Depth	600
Approach Angle (Degrees)	30.5
Departure Angle (Degrees)	24.2
Ramp Angle (Degrees)	22.9

LOAD BED (MM)	eDL40 Extended	eDL40 Double	eV-Cross
Length	1785	1520	1520
Width	1530	1530	1530
Depth	500	500	500

WEIGHTS (KG)			
Kerb Weight	2300	2345	2345
Gross Vehicle Weight	3360		
Payload	1060	1015	1015
Max Front Axle	1450		
Max Rear Axle	1910		
Trailer Weight Braked	3500		
Trailer Weight Unbraked	750		
Nose Weight	245		
Gross Train Weight	6000		

WHEELS & TYRES	
Tyres	265/60R18
Wheels	18x7.5J

INSURANCE GROUP	
Group	43A

Vehicle Dimensions

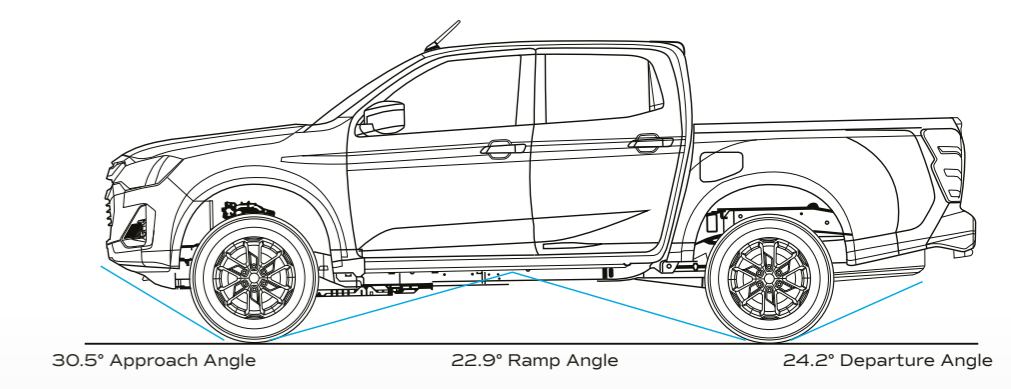
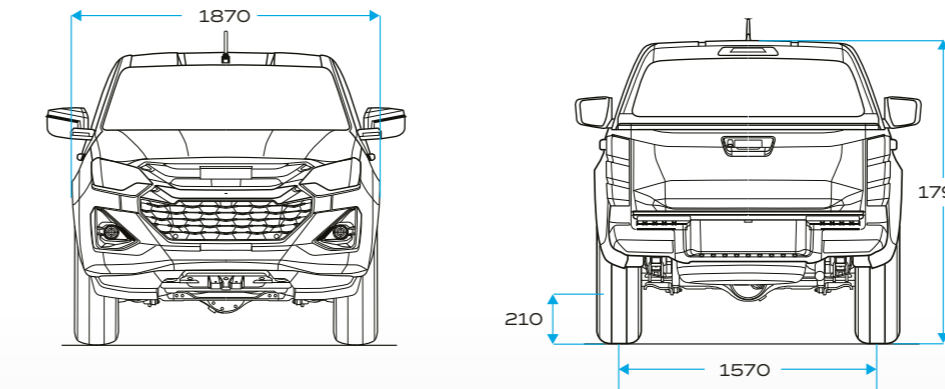
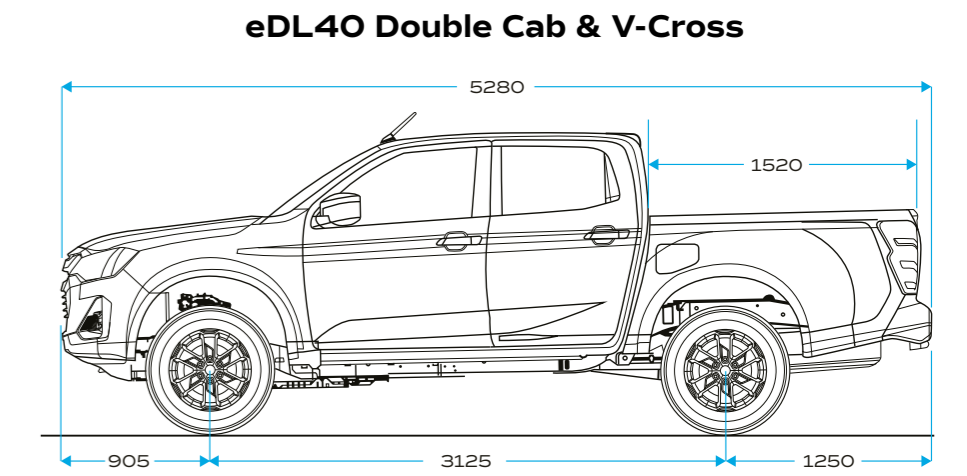
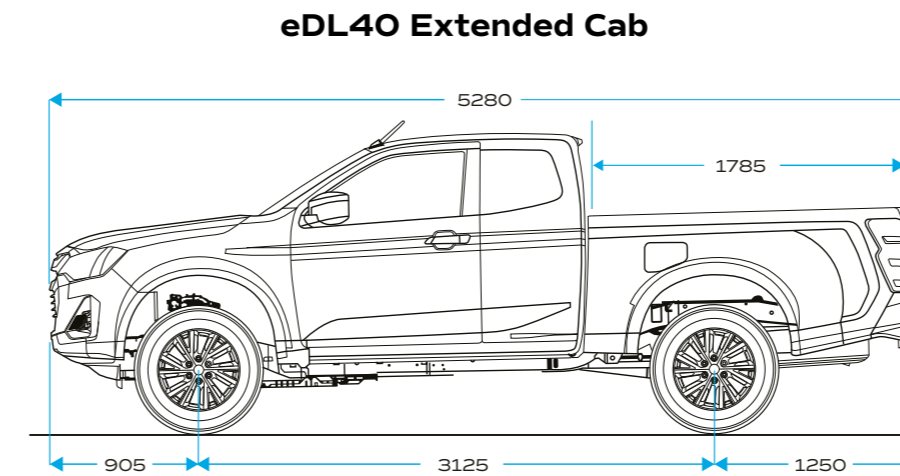

All measurements in mm.

¹MPG figures are EU test figures for comparative purposes and may not reflect real driving results. There is a new WLTP test used for fuel consumption and CO₂ figures. The fuel consumption and CO₂ emissions shown are based on the WLTP testing method. Only compare fuel consumption and CO₂ figures with other vehicles tested to the same technical standard. The fuel consumption you achieve in real life conditions and CO₂ produced will depend upon a number of factors including accessories fitted (post-registration), variations in weather, driving styles and vehicle load etc. ²Maximum payload capacity as defined by HM Revenue and Customs for VAT purposes. Payload is gross vehicle weight minus kerb weight. Kerb weights quoted are for vehicles with standard specification. Kerb weight and payload may be influenced by badge level, factory options and dealer fitted accessories. It is the responsibility of the vehicle operator to ensure their vehicle is legally compliant for road use.

Colours



SPLASH WHITE



MERCURY SILVER METALLIC



ONYX BLACK MICA



NEW MOUNTAIN GREY METALLIC
Available for eDL40 Double Cab & eV-Cross



BIARRITZ BLUE METALLIC
Available for V-Cross only



DOLOMITE WHITE PEARL
Available for eV-Cross only

Wheels



NEW eDL40 New Design 18" Two-Tone Alloy Wheels



NEW eV-CROSS New Design 18" Rugged Style Matt Dark Grey Alloy Wheels

Trim



NEW Leather Upholstery*

*Leather and other materials.



Isuzu (UK) Ltd reserves the right to change specifications and equipment without notice. Features and specification may vary in appearance and/or availability. For full details please contact your local Isuzu dealer or visit isuzu.co.uk



Isuzu (UK) Ltd a subsidiary of International Motors Limited.